

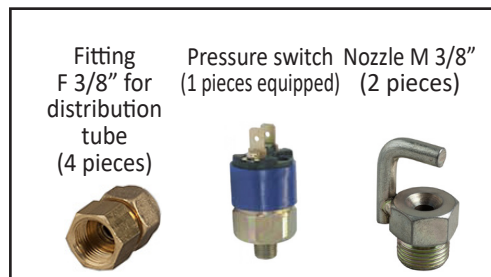

AUTOMATIC DEVICE "INDUSTRIAL SERIES" 3-6-12 Kg Powder



Included accessories



Fitting F 3/8" for distribution tube (4 pieces)
Pressure switch (1 piece equipped)
Nozzle M 3/8" (2 pieces)

Not Included accessories (only on request)

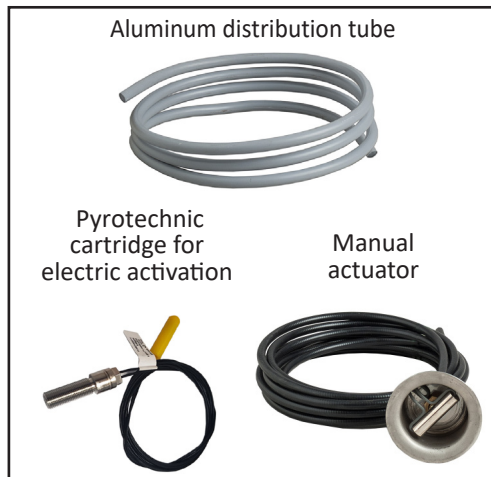

Aluminum distribution tube
Pyrotechnic cartridge for electric activation
Manual actuator

- **CYLINDER**
Alloy steel, epoxy polyester powder painting, Red Ral 3000.
- **EXTINGUISHING AGENT**
ABC Powder - MAP 20 %
- **PROPELLANT**
Nitrogen (N₂)
- **VALVE**
Automatic M. 30x1.5, set 93 °C. (with bulb in standard equipment)
Supplied with pressure switch set at 11 bar.
- **USE**
A B C fire rating (solid materials, flammable liquids, flammable gas).
- **ACTIVATION**
- Automatic when bulb temperature is reached. On request (see optional):
- with manual actuator with handle;
- with pyrotechnic cartridge for electric activation.
- **BRACKET**
Wall-mounted in standard equipment.

Note for pressure switch: The pressurized device is "normally open".
The pressure switch alone, not installed on the device, is "normally closed".

Note: image is for illustrative purpose only, the product purchased can have some differences

Powder Automatic Device, Industrial Series, available charge 3, 6, 12 Kg, temperature range from -30°C to +60°C, certified according to the directive for pressure equipment PED 2014/68/EU.

Quality Product certification guaranteed by Bureau Veritas Italia.

Suitable for use on fire involving electrical voltages up to 1'000 V, at a distance of 1 mt.

AVAILABLE VERSIONS

	POWDER QUANTITY	DIMENSIONS (without bracket) H x L max x Ø cylinder (mm)	M3/Kg	DISTRIBUTION TUBE LENGTH	DISCHARGE TIME	COVERAGE AREA
	Kg 3	440 +/-5 x 140 +/-3 x 130 +/-1	0,1373	recommended 4 m	20 sec.	5 sq.m
	Kg 6	490 +/-5 x 160 +/-3 x 160 +/-3	0,1373	recommended 6 m	35 sec.	10 sq.m
	Kg 12	590 +/-5 x 190 +/-3 x 190 +/-3	0,1373	recommended 8 m	60 sec.	20 sq.m

APPROVED/CERTIFIED DEVICE:



FIRE RATING :



AUTOMATIC DEVICE "INDUSTRIAL SERIES"

3-6-12 Kg Powder

TECHNICAL SPECIFICATIONS

FIRE RATING	A B C
EXTINGUISHING AGENT	EPW 18462 (ABC powder - MAP 20 %)
PROPELLANT	Nitrogen (N ₂) 15 Bar at 20°C
TEMPERATURE RANGE	-30°C / +60°C
CYLINDER PRESSURE TEST	PT 27 bar
VALVE TIGHTENING TORQUE	Between 40 and 50 Nm
CYLINDER MATERIAL	Alloy steel
EXTERNAL/INTERNAL TREATMENT	Sandblast and epoxy polyester powder painting, Red Ral 3000 colour

PACKAGING

STANDARD : single packaging

Note: the packaging quantities and measurements are indicative and can be subject at changes

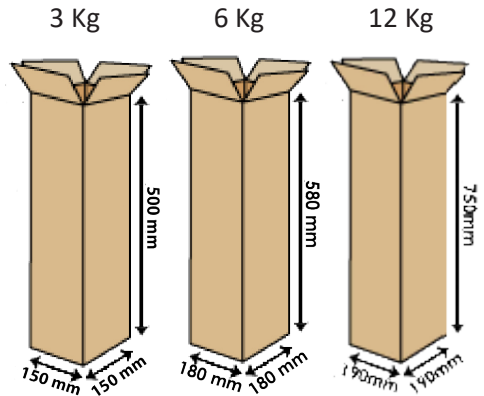

MAINTENANCE AND INSTALLATION

Install the system in vertical position using the supplied bracket. Place the distribution pipe and fix the nozzles. Remove the safety pin to make operating system.

Recommended maintenance : see specification in Use and Maintenance Manual equipped with the device, comply with the rules in use in utilization country.

EXAMPLE OF AUTOMATIC DEVICE INSTALLATION

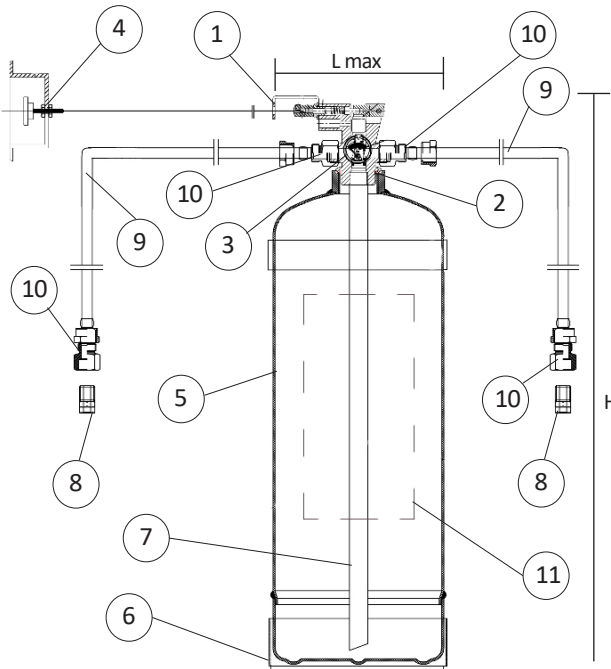

AVAILABLE THERMOSENSIBLE BULBS

ACTIVATION TEMPERATURE	68°C	93°C
BULB COLOUR	Red	Green
CODE	9510	9511

SPARE PARTS

N.	DESCRIPTION	
1	Valve M. 30x1.5 with thermosensible bulb for activation at 93°C	
2	Valve o-ring	
3	Pressure gauge	
4 - OPTIONAL	Manual actuator in control box(cable 10 m)	
5	Cylinder 3 Kg Cylinder 6 Kg Cylinder 12 Kg	
6	Iron bracket 3 Kg Iron bracket 6 Kg Iron bracket 12 Kg	
7	PVC dip tube 3 Kg PVC dip tube 6 Kg PVC dip tube 12 Kg	
8	Dispensing nozzle AVP M 3/8"	
9 - OPTIONAL	Aluminum distribution tube Ø 10, PVC coated	
10	Fitting F 3/8" for distribution tube	
OPTIONAL	Pyrotechnic cartridge	
11	Label	
	Pressure switch 1/8" for valve, set at 11 bar	