



## 12Kg Powder AUTOMATIC FIRE EXTINGUISHER



*Note: image is for illustrative purpose only, the product purchased can has some differences*

- **CYLINDER**  
Alloy steel, 2 pieces, with protection for valve, epoxy polyester powder painting, Red Ral 3000.
- **EXTINGUISHING AGENT**  
ABC powder.
- **PROPELLANT**  
Dehumidified air or N<sub>2</sub>.
- **VALVE**  
Sprinkler M 30X1.5, set to 68 °C.
- **USE**  
A B C fire rating  
(solid materials, flammable liquids, flammable gas).
- **BRACKET**  
Bracket for ceiling mounting.

© REPRODUCTION IS PROHIBITED

12Kg powder automatic fire extinguisher, temperature range from -30°C to +60°C, certified according to the directive for pressure equipment PED 2014/68/EU.

Quality Product certification guaranteed by Bureau Veritas Italia.

Suitable for use on fire involving electrical voltages up to 1'000 V, at a distance of 1 mt.

APPROVED/CERTIFIED FIRE EXTINGUISHER



**FIRE RATING :**



# 12Kg Powder AUTOMATIC FIRE EXTINGUISHER

## TECHNICAL SPECIFICATIONS

FIRE RATING	A B C
EXTINGUISHING AGENT	ABC powder - MAP 20 %
PROPELLANT	Dehumidified air or N2, 14 Bar at 20°C
TEMPERATURE RANGE	-30°C +60°C
NOMINAL CHARGE	12 Kg
FULL WEIGHT	~ 18 Kg
DIMENSIONS	Height 360 +/- 5 mm Diameter 360 +/- 2 mm
COVERAGE AREA	~ 12 sq.m
DISCHARGE TIME	~ 14 sec.
VALVE TIGHTENING TORQUE	Minimum 45 Nm, Maximum 68 Nm
CYLINDER PRESSURE TEST	PT 27 bar
CYLINDER VOLUME	13,5 L.
SAFETY DEVICE	Set between 22 and 27 bar
CYLINDER MATERIAL	Alloy steel
EXTERNAL TREATMENT	Sandblast and epoxy polyester powder painting, Red Ral 3000 colour

## PACKAGING

max 27 pieces for pallet 100x120

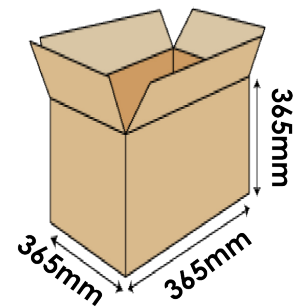

*Note: the packaging quantities and measurements are indicative and can be subject at changes*

## MAINTENANCE AND INSTALLATION

Recommended installation max 3 m. from ground. Do not expose to direct sunlight. Maintenance according to the norm in use in utilization country.

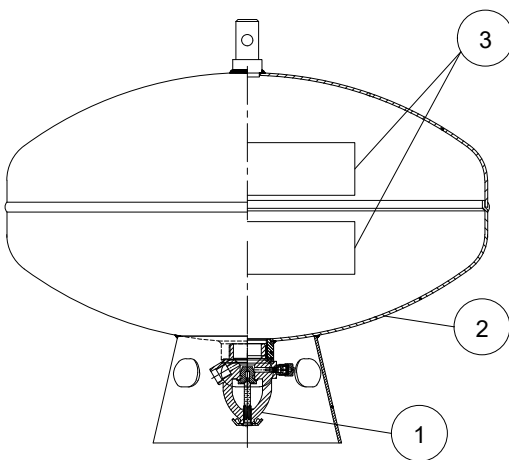

## SPARE PARTS

NUMBER	DESCRIPTION	
1	Valve M 30 X 1.5 with thermosensible bulb for activation at 68°C	
2	Cylinder	
3	Label	