



## 50 Kg Powder WHEELED FIRE EXTINGUISHER



*Note: image is for illustrative purpose only, the product purchased can has some differences*

- **CYLINDER**  
Alloy steel, epoxy polyestere powder painting, Red Ral 3000.
- **EXTINGUISHING AGENT**  
ABC Powder - MAP 20 %.
- **PROPELLANT**  
Aria deumidificata o N<sub>2</sub>.
- **VALVE**  
2"-F, brass body, lever with red painting Ral 3000.
- **USE**  
A B C fire rating (solid materials, flammable liquids, flammable gas).
- **BRACKET**  
Chassis on wheels, welded at the cylinder, red painting Ral 3000.

© REPRODUCTION IS PROHIBITED

50 kg powder wheeled fire extinguisher, temperature range from -30°C to +60°C, manufactured in accordance to **EN 1866-1**, certified according to the directive for pressure equipment PED 2014/68/EU. Quality Product certification guaranteed by Bureau Veritas Italia. Suitable for use on fire involving electrical voltages up to 1'000 V, at a distance of 1 mt.

APPROVED/CERTIFIED FIRE EXTINGUISHER:



**FIRE RATING :**



# 50 Kg Powder WHEELED FIRE EXTINGUISHER

## TECHNICAL SPECIFICATIONS

FIRE RATING	A III B C
EXTINGUISHING AGENT	EPW 18462 (ABC Favorit Tertia) ABC Powder - MAP 20 %
PROPELLANT	Dehumidified air or N <sub>2</sub> ,14 Bar at 20°C
TEMPERATURE RANGE	-30°C / +60°C
NOMINAL CHARGE	50 Kg
FULL WEIGHT	~ 79 Kg
DIMENSIONS	Height 1100 mm Width 480 mm Depth 480 mm
DISCHARGE TIME	50 sec.
VALVE TIGHTENING TORQUE	Minimum 60 Nm, Maximum 70 Nm
CYLINDER PRESSURE TEST	PT 30 bar
CYLINDER VOLUME	62 L.
SAFETY VALVE	Set 24 +/- 2 bar
CYLINDER MATERIAL	Alloy steel
EXTERNAL/INTERNAL TREATMENT	Sandblast and epoxy polyester powder painting, Red Ral 3000 colour

## PACKAGING

STANDARD : maximum 6 pieces for pallet  
Pallet dimensions 100x120x135(h) cm

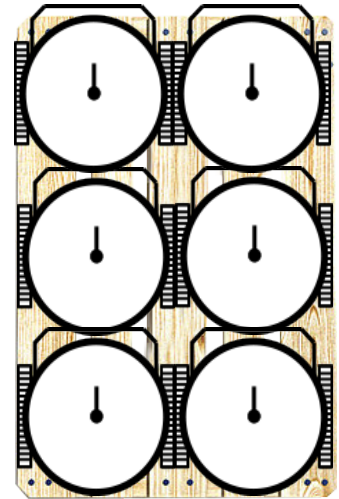

*Note: the packaging quantities and measurements are indicative and can be subject at changes*

## MAINTENANCE AND INSTALLATION

For outdoor or marine installation is recommended to protect the fire extinguisher with cover. Maintenance according to the norm in use in utilization country.

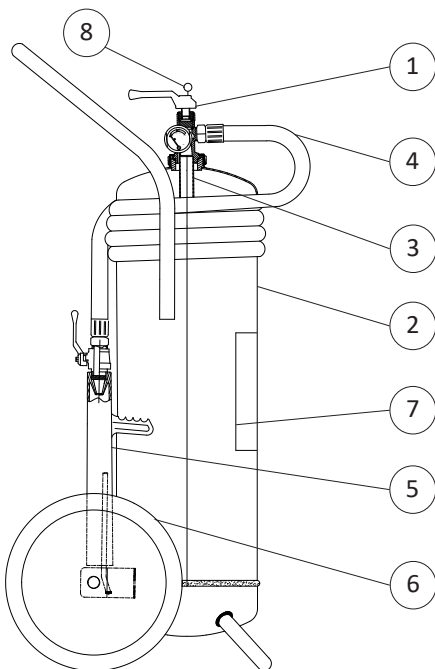

## SPARE PARTS

NUMBER	DESCRIPTION	
1	Valve 2''-F	
2	Cylinder	
3	PVC dip tube	
4	Hose	
5	Dispensing nozzle (complete of ball valve with control lever)	
6	Wheel + wheel stop (diam. 300mm)	
7	Label	
8	Safety pin	
	Safety valve	
	Safety pin seal	
	ABC powder - MAP 20 % (25 Kg recharge)	